

FEMALE END VIEW

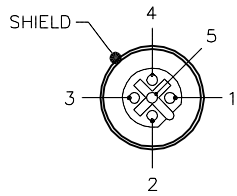

- 1 = BROWN
- 2 = WHITE
- 3 = BLUE
- 4 = BLACK
- 5 = GRAY



SPECIFICATIONS

CONTACT CARRIER MATERIAL	NYLON OR TPU
MOLDED HEAD MATERIAL/COLOR	TPU/YELLOW
CONTACT MATERIAL/PLATING	BRASS/GOLD
COUPLING NUT MATERIAL/PLATING	BRASS/NICKEL
RATED CURRENT [A]	4.0 A
RATED VOLTAGE [V]	250 V
OUTER CABLE JACKET MATERIAL/COLOR	TPU/BLACK
CONDUCTOR INSULATION MATERIAL	PVC
NUMBER OF CONDUCTORS [AWG]	5x22 AWG
DRAIN/SHIELD	24 AWG/ALUM.-POLYESTER FOIL & T-C BRAIDED
TEMPERATURE RANGE	-40°C to +80°C (-40°F to +176°F)
PROTECTION CLASS	MEETS IEC IP67

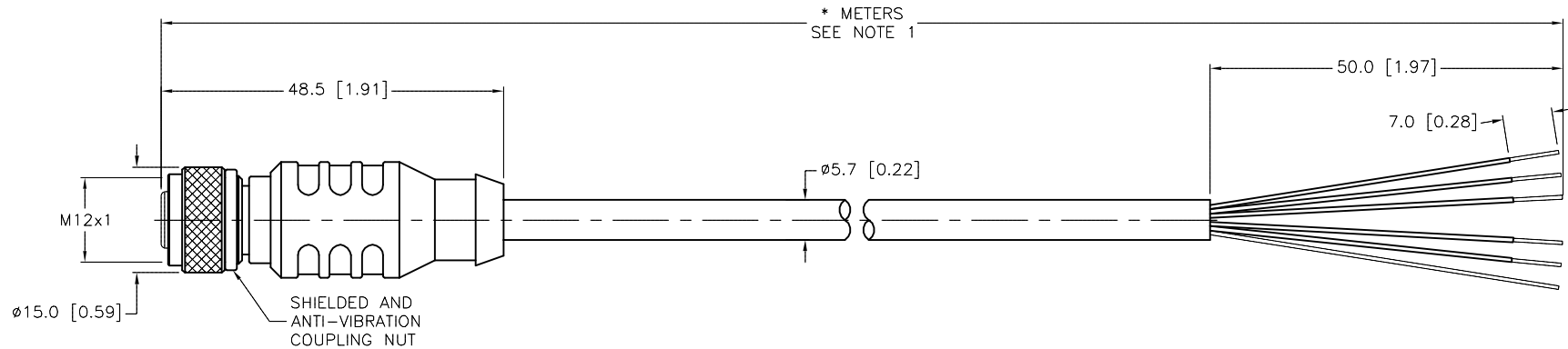

CABLE LENGTH	TOLERANCE*
ALL LENGTHS	+ 4% (OR 50mm) OF LENGTH - 0% (OR 0mm) OF LENGTH WHICHEVER IS GREATER
STRIP LENGTH	TOLERANCE*
0-7mm	±0.5mm
8-29mm	±1.0mm
30-49mm	±2.0mm
50-69mm	±3.0mm
70-100mm	±4.0mm
OVER 100mm	±5.0mm

* UNLESS OTHERWISE SPECIFIED

NOTES:

- "*" INDICATES CABLE LENGTH IN METERS. CONTACT TURCK TO ORDER SPECIFIC LENGTHS.
- "/S760" DESIGNATES BLACK CABLE JACKET.
- "/S3034" DESIGNATES YELLOW MOLDED PLUG BODY.
- "/S3090" DESIGNATES THERMOPLASTIC POLYURETHANE (TPU) CABLE JACKET WITH +80°C TEMPERATURE RATING.

SOURCE DRAWING - FOR REFERENCE ONLY

RELATED DOCUMENTS	3RD ANGLE PROJECTION	THIS DRAWING IS CONFIDENTIAL AND THE PROPERTY OF TURCK INC. USE OF THIS DOCUMENT WITHOUT WRITTEN PERMISSION IS PROHIBITED.		3000 CAMPUS DRIVE MINNEAPOLIS, MN 55441 1-800-544-7769 (763) 553-7300 (763) 553-0708 fax turck.com	
1.		DRFT	RDS	DATE	06/10/15
2.		APVD	L.H.	SCALE	1=1.0
3.	ALL DIMENSIONS DISPLAYED ON THIS DRAWING ARE FOR REFERENCE ONLY	UNIT OF MEASUREMENT			DESCRIPTION
4.		MILLIMETER [INCH]			RKSW 4.5T-*/S760/S3034/S3090
MATERIAL	CONTACT TURCK FOR MORE INFORMATION	IDENTIFICATION NO.			REV
SEE SPECIFICATIONS					A
FINISH	DO NOT SCALE THIS DRAWING	FILE: 777035593			SHEET 1 OF 1
SEE SPECIFICATIONS					

A	DRAWING RELEASE	RDS	06/18/15	
REV	DESCRIPTION	BY	DATE	ECO NO.